

Serie Up 2000

ARMCHAIRS

2000

Gaetano Pesce

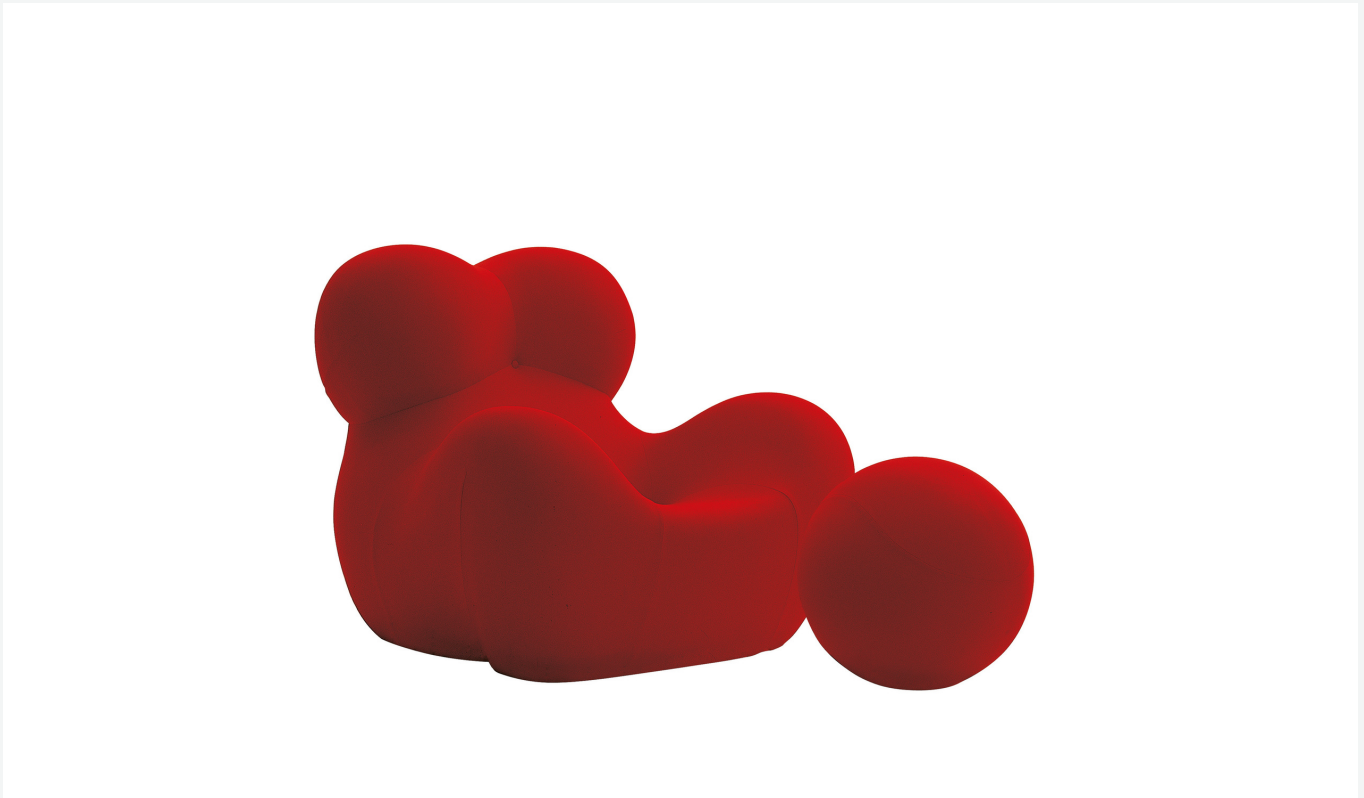

Description

Designed in 1969, right from the onset the Up series has been one of the most outstanding expressions of design with its expressive shapes upholstered with elastic fabric. This innovative solution, poised midway between design and art, and conceived to be offered to a wide audience, stems from B&B Italia's extensive technological know-how in terms of polyurethane injection moulding. Particularly noteworthy among the armchairs is the iconic UP5_6, with its unmistakable anthropomorphic references: a metaphor of a large womb, it calls to mind ancient statues of the goddesses of fertility. But that's not all: a spherical ottoman tied to the armchair contrasts the image of comfort and convenience with a more figurative one of a woman with a ball and chain tied to her foot. Gaetano Pesce described the project as follows: "At that time, I was seeking to tell a personal story about my concept of women: I believe that women have always unwittingly been their own jailer. This is why I decided to give this armchair the shape of a woman with a ball and chain, reflecting the traditional image of a prisoner". This armchair also comes in a junior version for kids aged 3 and up – a perfectly faithful replica of the original design, only smaller. The series also includes the UP7 "foot", a large sculptural object in painted polyurethane that poses as an archaeological relic of the modern era.

SERIE UP designed in 1969 by Gaetano Pesce wins XXVII Compasso d'Oro ADI - Product Career Award 2022.

Technical information

Upholstery

Bayfit® flexible cold shaped polyurethane foam

Bottom base

100% jute fabric, PVC trimming

Cover button

metallic base and fabric

Bottom base button

thick leather

Cord (UP5_6)

100% nylon

Finish (UP7)

polyurethane

Cover

fabric in limited categories

Technical drawings

UP1

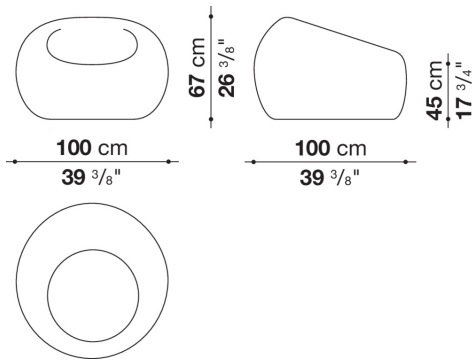

UP2

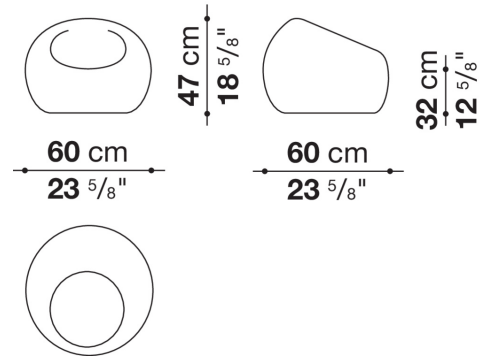

UP3

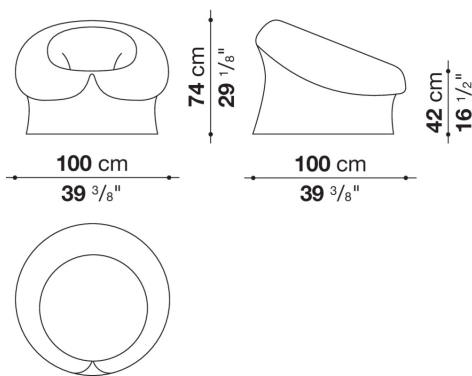

UP7

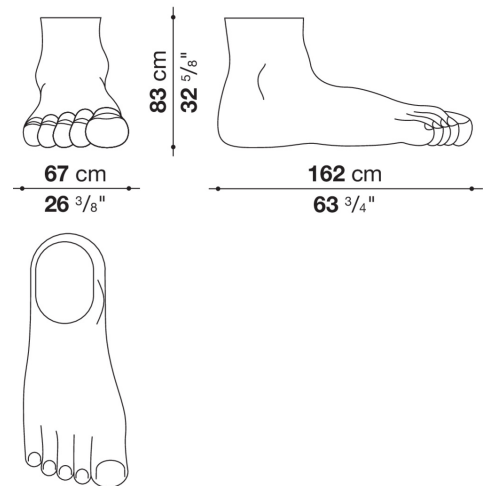

UP5_6

