

W02
SARPI OFFICE1974
CARLO SCARPA

ENG Carlo Scarpa designed this masterpiece in 1974, successor to the popular sculptural Doge table, part of the home collection. While alluding to the same textural features as its predecessor, the new base is upside-down and has a smaller footprint, allowing the table to also be used in smaller office spaces. The table comes with cable slot located at the center of the top, with the option of various electrical configurations.

ITA Carlo Scarpa disegna questo capolavoro nel 1974, sulla scia del successo dello scultoreo tavolo Doge parte della collezione residenziale. Pur citando le stesse caratteristiche materiche del suo predecessore, il nuovo basamento risulta capovolto e di dimensioni ridotte per consentire di utilizzare il tavolo anche in contesti office contenuti. Il tavolo è predisposto all'elettrificazione con foro passacavi situato al centro del piano con la possibilità di diverse configurazioni elettriche.

FRA Carlo Scarpa a conçu ce chef-d'œuvre en 1974, dans le sillage du succès de la table sculpturale Doge qui fait partie de la collection résidentielle. Tout en revendiquant les mêmes matériaux que son prédécesseur, le nouveau piètement est renversé et de taille réduite pour permettre une utilisation de la table même dans des bureaux exigus. La table intègre un passe-câble au centre du plateau qui permet différentes configurations électriques.

DE Carlo Scarpa entwirft dieses Meisterwerk im Jahre 1974 nach dem Erfolg des Tisches Doge, der zur Kollektion der Wohneinrichtungen gehört. Er nimmt zwar die architektonischen Merkmale seines Vorgängers auf, die neue Basis ist jedoch umgekehrt ausgeführt und weist geringere Maße auf, damit der Tisch auch in kleineren Büroräumen verwendet werden kann. Der Tisch ist mit einer Öffnung in der Tischmitte zur Kabeldurchführung für verschiedene elektrische Anschlussmöglichkeiten vorgerüstet.

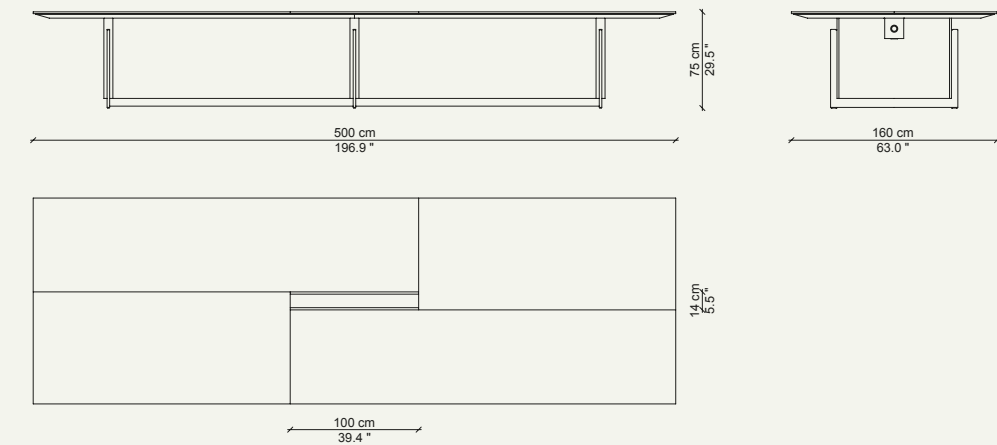

W02 - 31

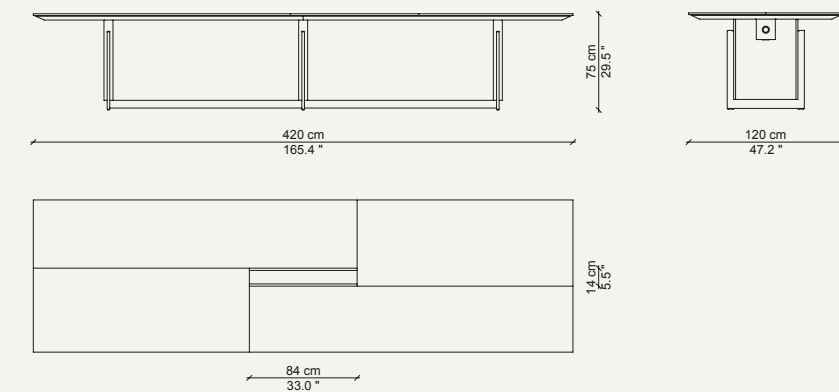

W02 - 34

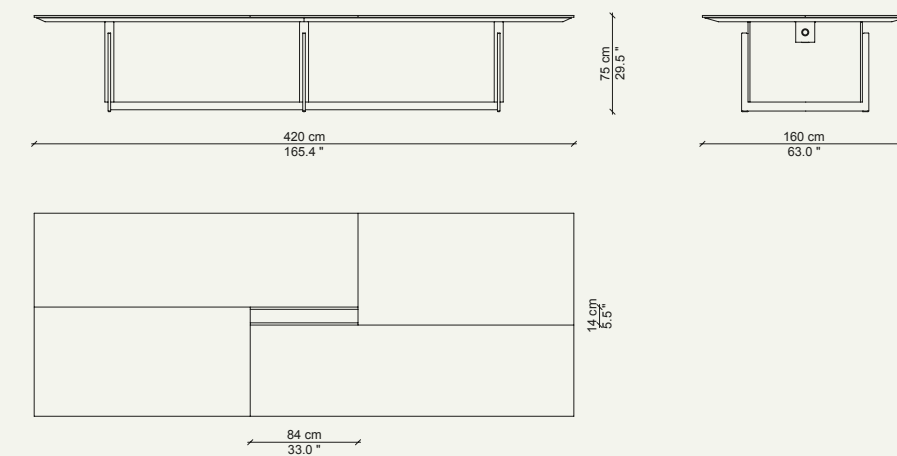

W02 - 32

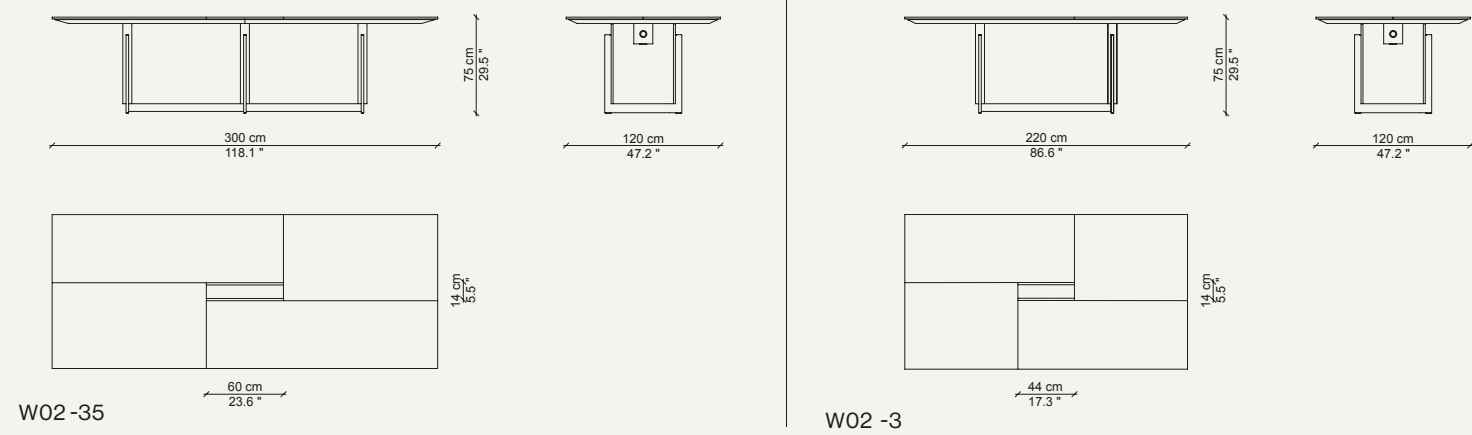

W02-35

W02-3

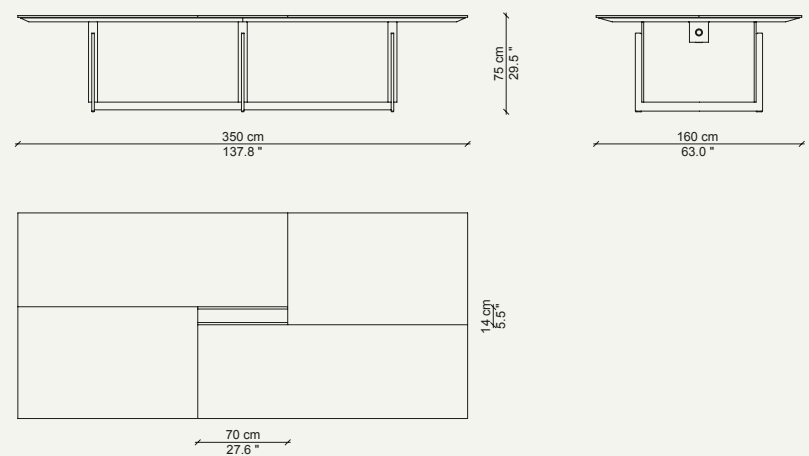

W02-33

FINISHES - FINITURE - FINITIONS - AUSFÜHRUNGEN

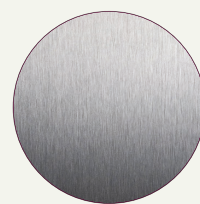

Steel
Acciaio
Acier
Stahl



American walnut
Noce Canaletto
Noyer américain
Amerikanischer Nußbaum



Black stained ashwood
Frassino tinto nero
Chêne teinté noir
Esche schwarz gebeizt

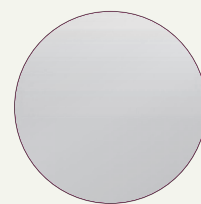

White lacquered glass
Vetro retrolaccato bianco
Verre laqué blanc
Glas weiß lackiert

ENG STRUCTURE In drawn metal with satin finish and protective transparent paint. Exposed burnished screws. TOP Canaletto walnut, ash stained black or glass back-lacquered white. FEET Feet in black rubber.

ITA STRUTTURA Struttura in metallo trafilato satinato protetta con vernice trasparente. Viti brunate a vista. PIANO Noce canaletto, frassino tinto nero o vetro retrolaccato bianco. PIEDINI Piedini in gomma nera.

FRA STRUCTURE Structure en métal étiré satiné, protégé par un vernis transparent. Vis brunies apparentes. PLATEAU Noyer Canaletto, frêne teinté noir ou verre laqué blanc. EMBOUTS Embouts en caoutchouc noir.

DE GESTELL Gestell Metallvollprofil satiniert, mit transparentem Schutzlack. Schrauben brüniert in Sicht. TISCHPLATTE Nussbaum Canaletto, Esche gebeizt in Schwarz oder Glas mit Rückseite mit Lackierung in Weiß. FÜSSE Füße aus schwarzem Gummi.

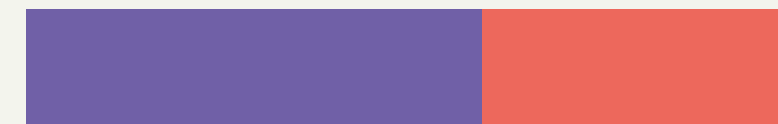

SARPI OFFICE (500X160 WOOD)

● 58,8% Wood ● 0,1% Plastic
● 41% Metal

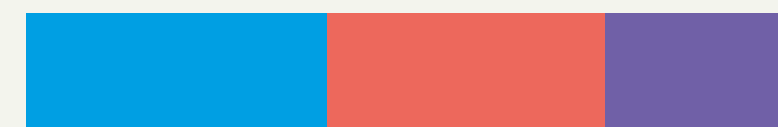

SARPI OFFICE (500X160 GLASS)

● 39% Glass ● 24,9% Wood
● 36% Metal ● 0,1% Plastic



SARPI OFFICE (220X120 WOOD)

● 54% Wood ● 0,2% Plastic
● 45,8% Metal



SARPI OFFICE (220X120 GLASS)

● 42% Metal ● 26% Glass
● 31,8% Wood ● 0,2% Plastic

CERTIFICATIONS - CERTIFICAZIONI - CERTIFICATIONS - ZERTIFIKATE

BIFMA

CABLE MANAGEMENT - GESTIONE CAVI - GESTION DES CÂBLES - KABELMANAGEMENT

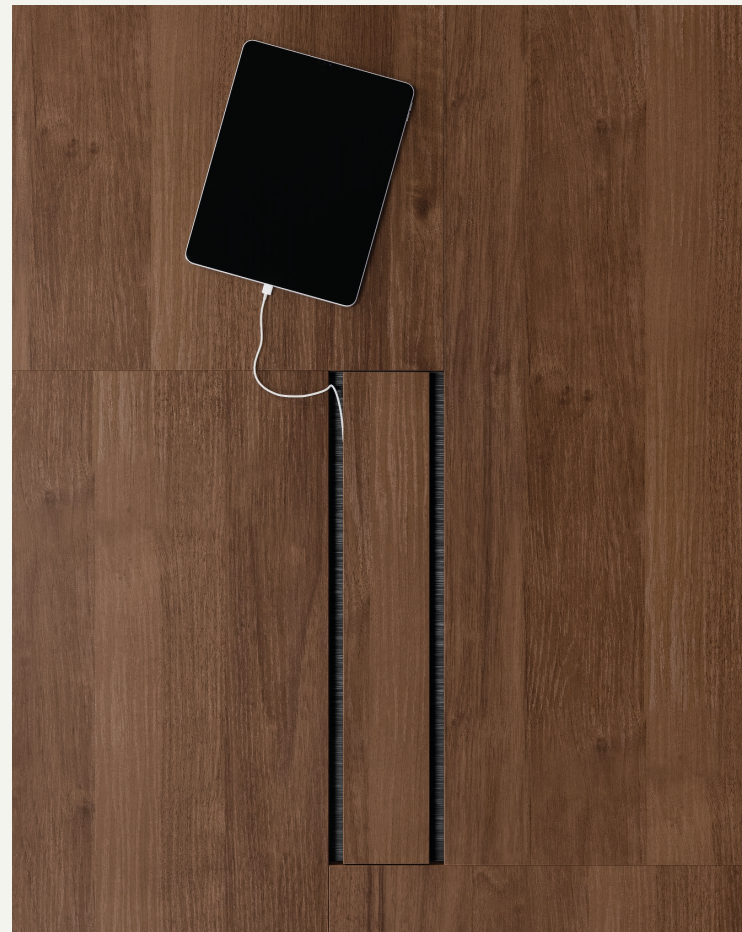
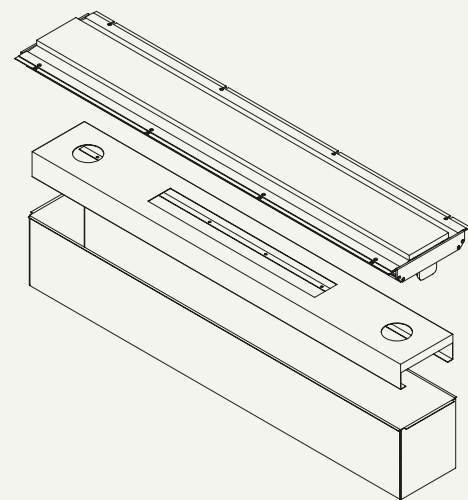
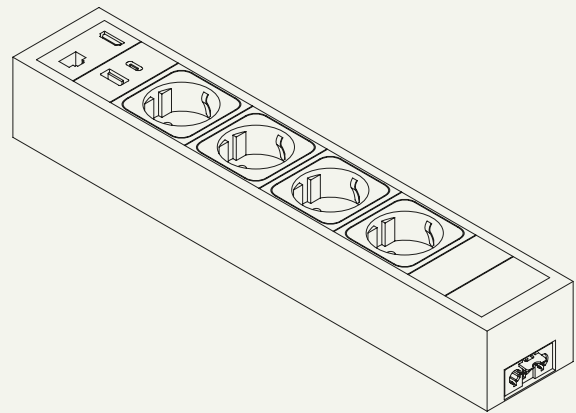
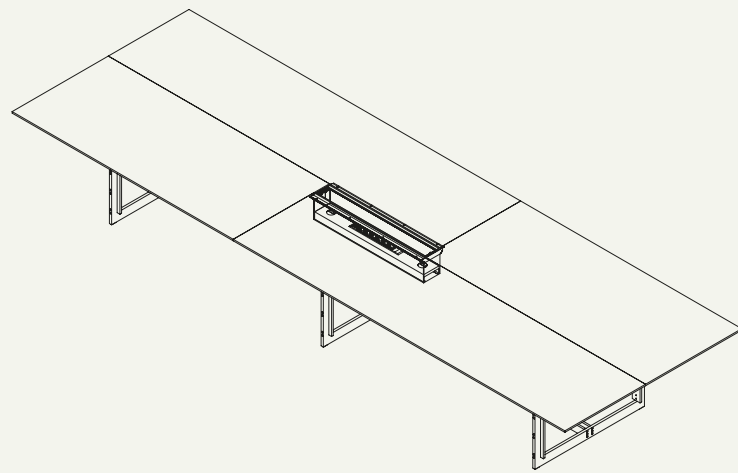

PRESE - SOCKETS - PRISE - STECKDOSE



UNEL



UK



USA



UNI

USB COMPONENTS & MULTIMEDIA
COMPONENTI USB E MULTIMEDIA
COMPOSANTS USB ET MULTIMÉDIA
USB-KOMPONENTEN UND MULTIMEDIA



USB SWITCH
USB RICARICA
CHARGEMENT USB
USB-AUFLADUNG



USB TYPE-A



USB TYPE-C

