

# ELIOT KERAMIK DRIVE

Design: Giorgio Cattelan

## DIMENSIONS

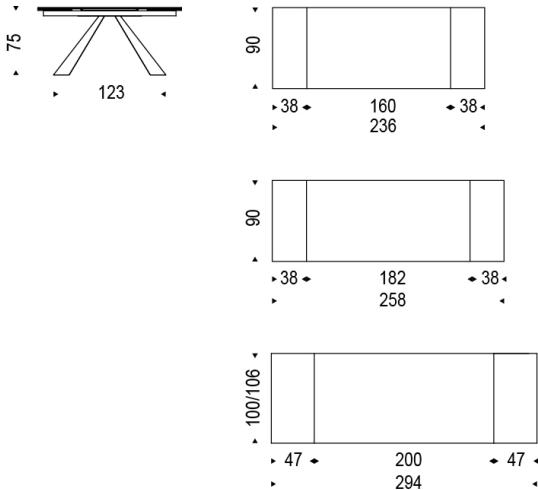

160/236x90x75h  
182/258x90x75h  
200/294x100x75h  
200/294x106x75h

## DESCRIPTION

Extendible table with base in white or graphite embossed lacquered steel or in satin stainless steel. Laminam Fokos ceramic top and extensions in salt or lead colours or in Marmi ceramic in Calacatta or black Travertino colours.

## FINISHES: base

### metal



## FINISHES: top

### Fokos ceramic



### Marmi ceramic

