

SPIO
design AL Studio e Carlesi Design

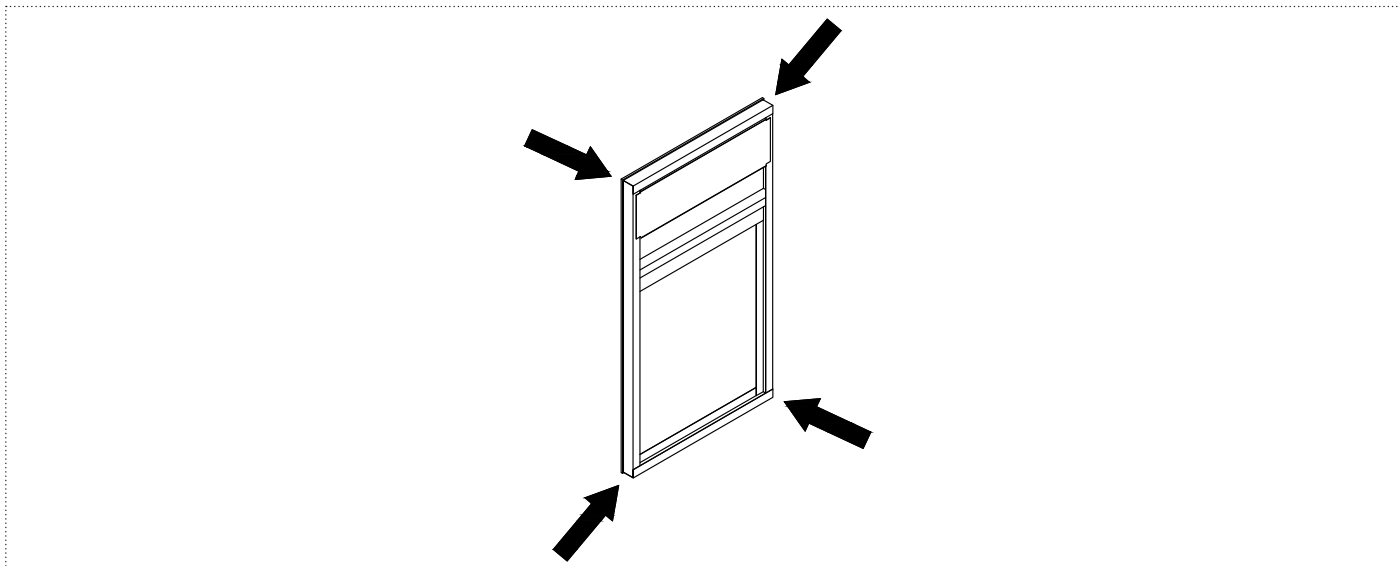

antoniolupi

MADE IN ITALY



P.S.: REMOVE THE CORNER PROTECTION ONLY WHEN ISNTALLATION IS COMPLETED.
 WE ADVISE TO MAKE SURE THE LIGHTING WIRES ARE PREPARED SO THEY ARE IN CORRESPONDENCE TO THE CENTER OF THE MIRROR.

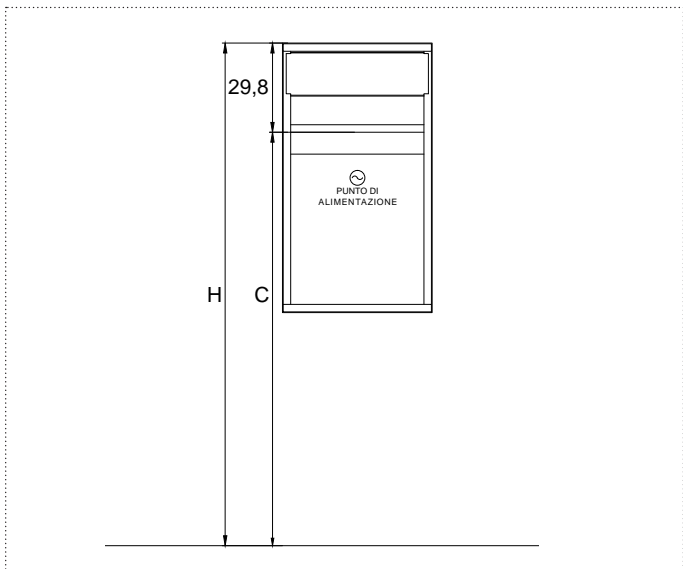

1_ To attach the mirror to the desired height H. Mark the position of the fixing holes of the brackets S, in such a way that the fold of such is located at the height C ($C = H - 7,4$ cm).

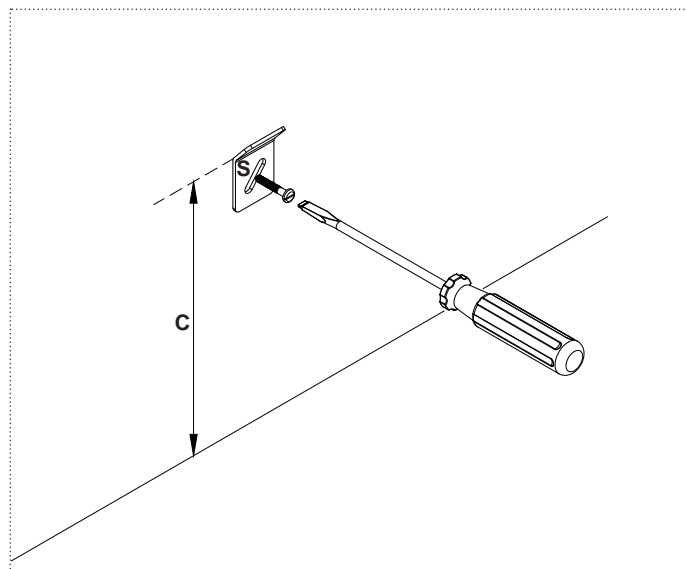

2_ Fix the bracket S at the determined height, put the second bracket in level with the first and fasten it to the wall.

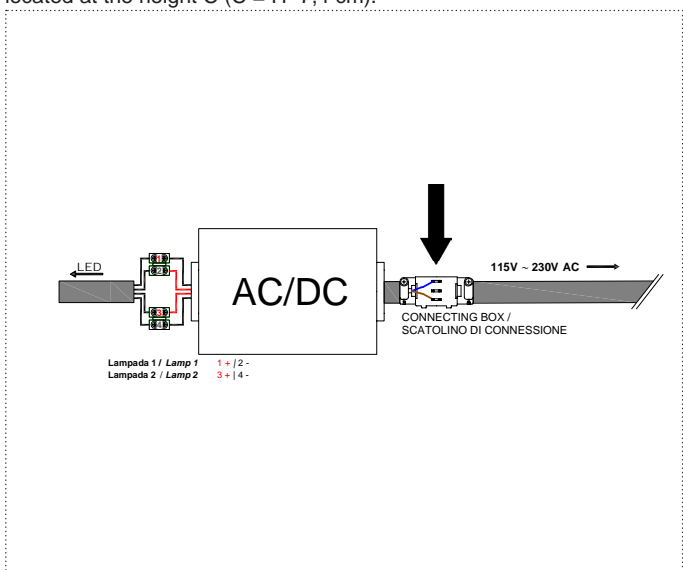

3_ Make the electrical connection between the network and the AC adapter / DC, using the small box of the supplied connection as indicated.

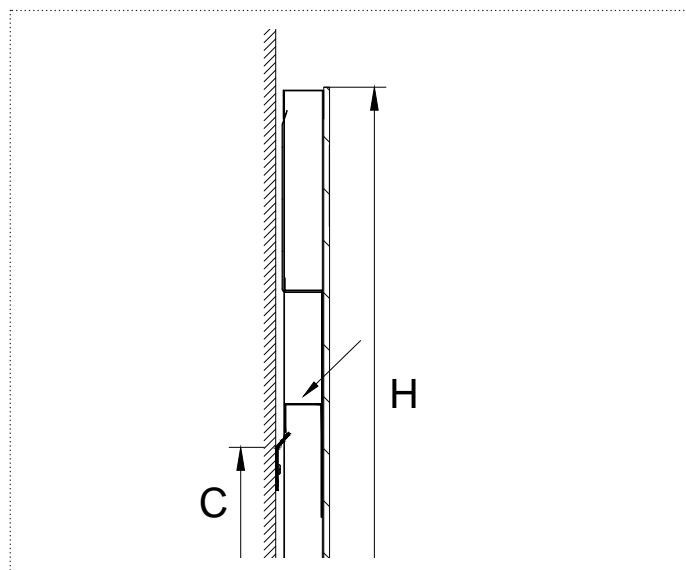

4_ Hang the mirror

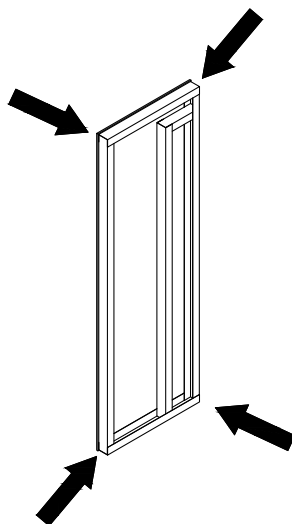

P.S.: REMOVE THE CORNER PROTECTION ONLY WHEN ISNTALLATION IS COMPLETED.
WE ADVISE TO MAKE SURE THE LIGHTING WIRES ARE PREPARED SO THEY ARE IN CORRESPONDENCE TO THE CENTER OF THE MIRROR.

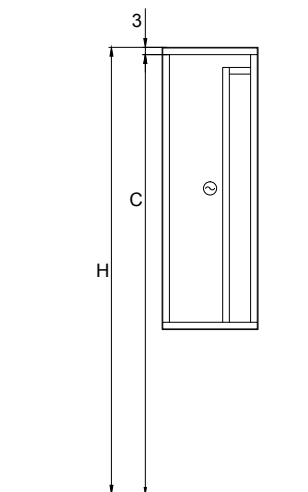

1_ To attach the mirror to the desired height H. Mark the position of the fixing holes of the brackets S, in such a way that the fold of such is located at the height C ($C = H - 7,4$ cm).

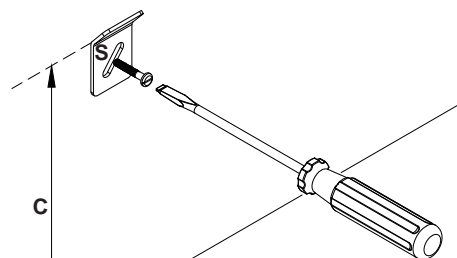

2_ Fix the bracket S at the determined height, put the second bracket in level with the first and fasten it to the wall.

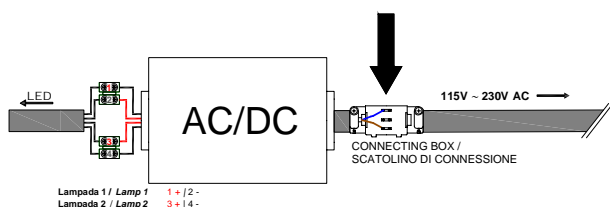

3_ Make the electrical connection between the network and the AC adapter / DC, using the small box of the supplied connection as indicated.

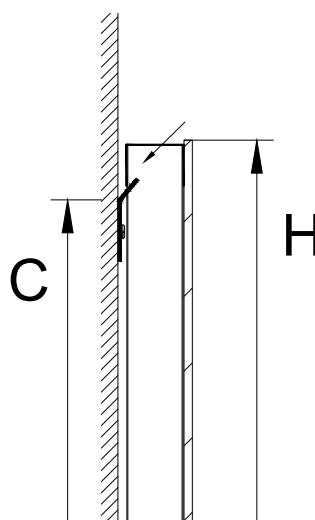

4_ Hang the mirror

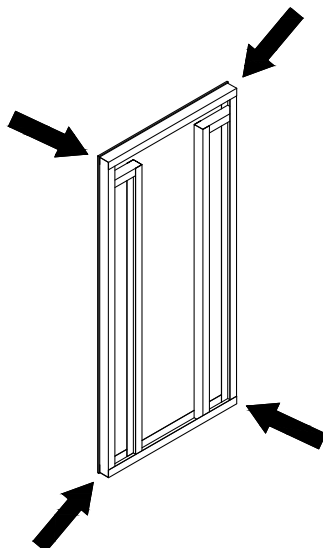

P.S.: REMOVE THE CORNER PROTECTION ONLY WHEN ISNTALLATION IS COMPLETED.
WE ADVISE TO MAKE SURE THE LIGHTING WIRES ARE PREPARED SO THEY ARE IN CORRESPONDENCE TO THE CENTER OF THE MIRROR.

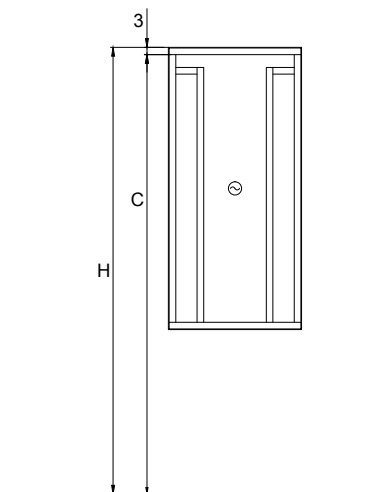

1_ To attach the mirror to the desired height H. Mark the position of the fixing holes of the brackets S, in such a way that the fold of such is located at the height C ($C = H - 7,4$ cm).

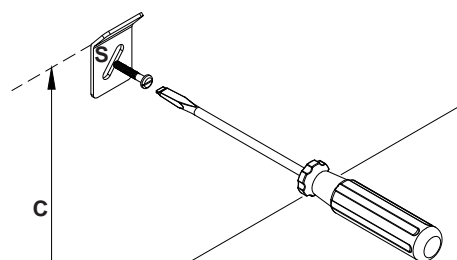

2_ Fix the bracket S at the determined height, put the second bracket in level with the first and fasten it to the wall.

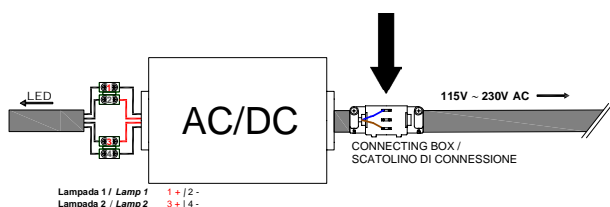

3_ Make the electrical connection between the network and the AC adapter / DC, using the small box of the supplied connection as indicated.

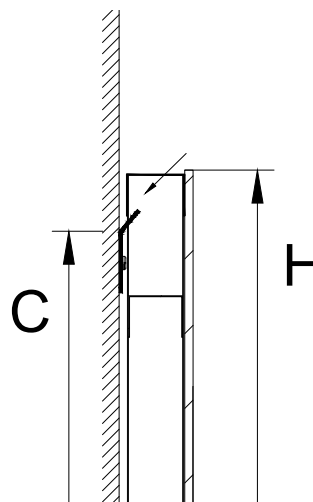

4_ Hang the mirror

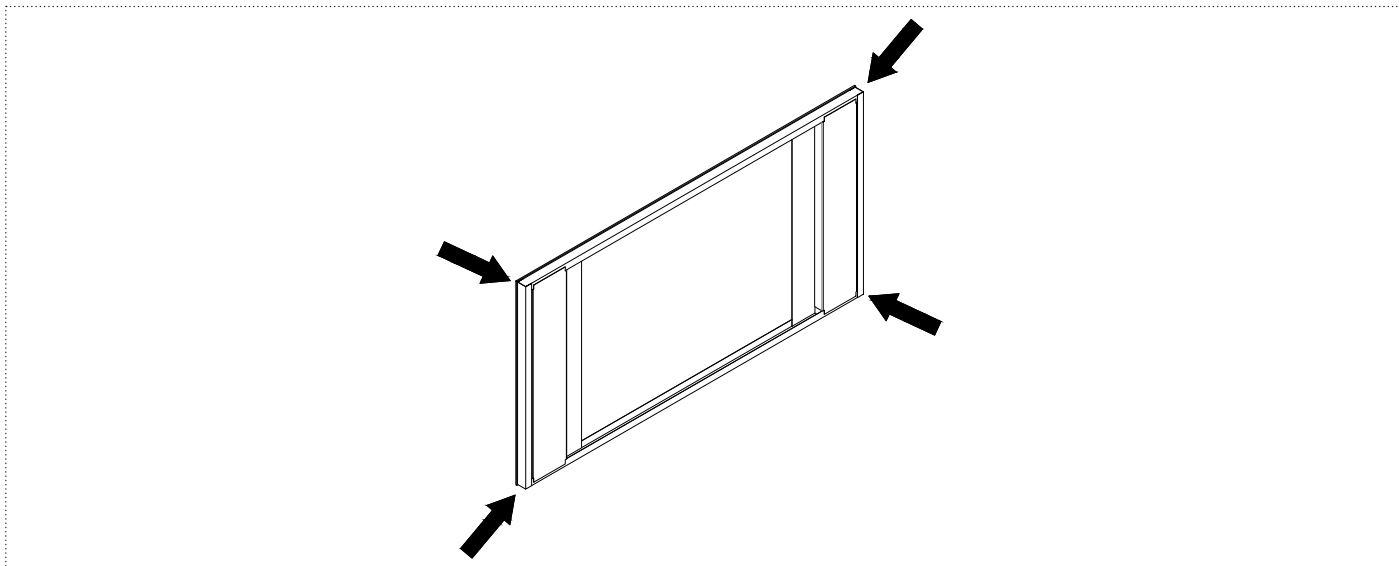

P.S.: REMOVE THE CORNER PROTECTION ONLY WHEN ISNTALLATION IS COMPLETED.
WE ADVISE TO MAKE SURE THE LIGHTING WIRES ARE PREPARED SO THEY ARE IN CORRESPONDENCE TO THE CENTER OF THE MIRROR.

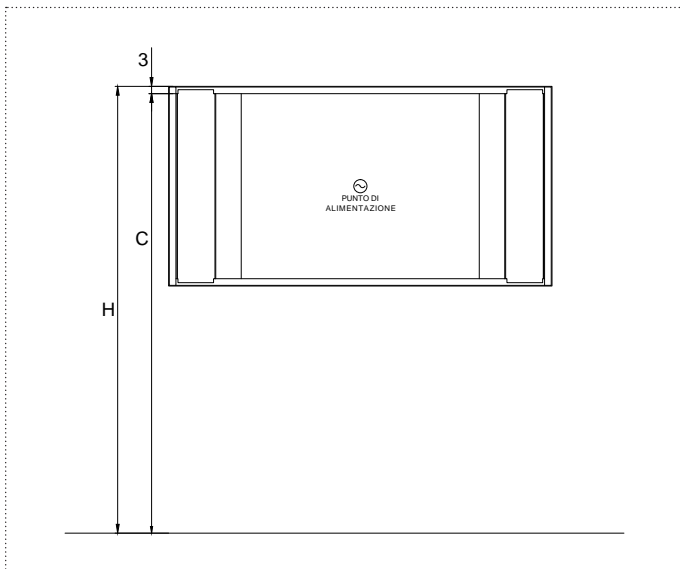

1_ To attach the mirror to the desired height H. Mark the position of the fixing holes of the brackets S, in such a way that the fold of such is located at the height C ($C = H - 7,4$ cm).

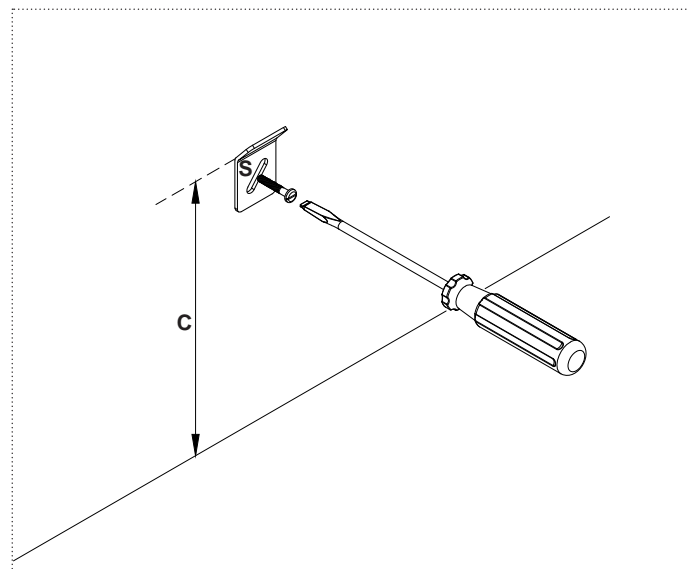

2_ Fix the bracket S at the determined height, put the second bracket in level with the first and fasten it to the wall.

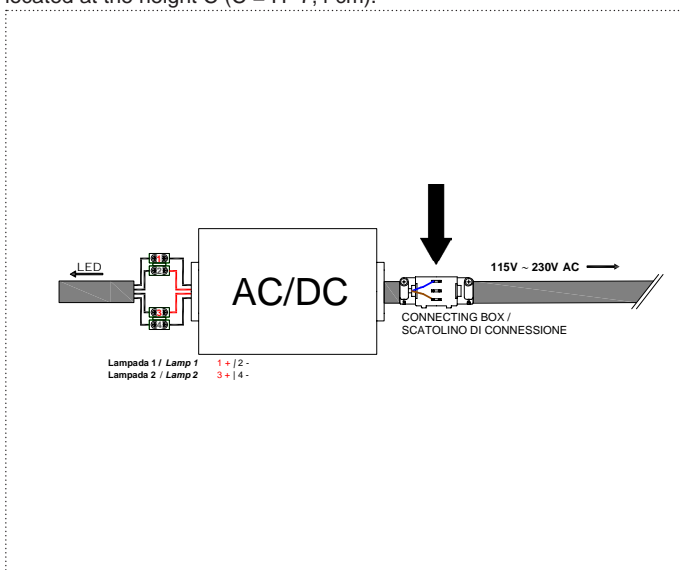

3_ Make the electrical connection between the network and the AC adapter / DC, using the small box of the supplied connection as indicated.

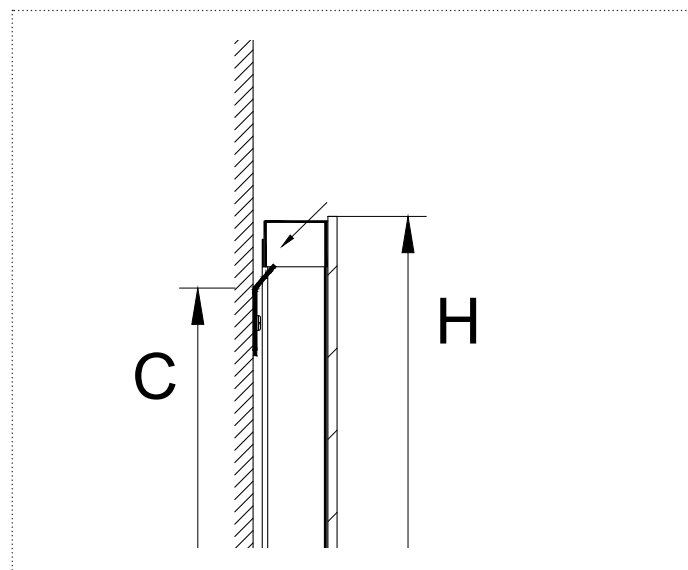

4_ Hang the mirror

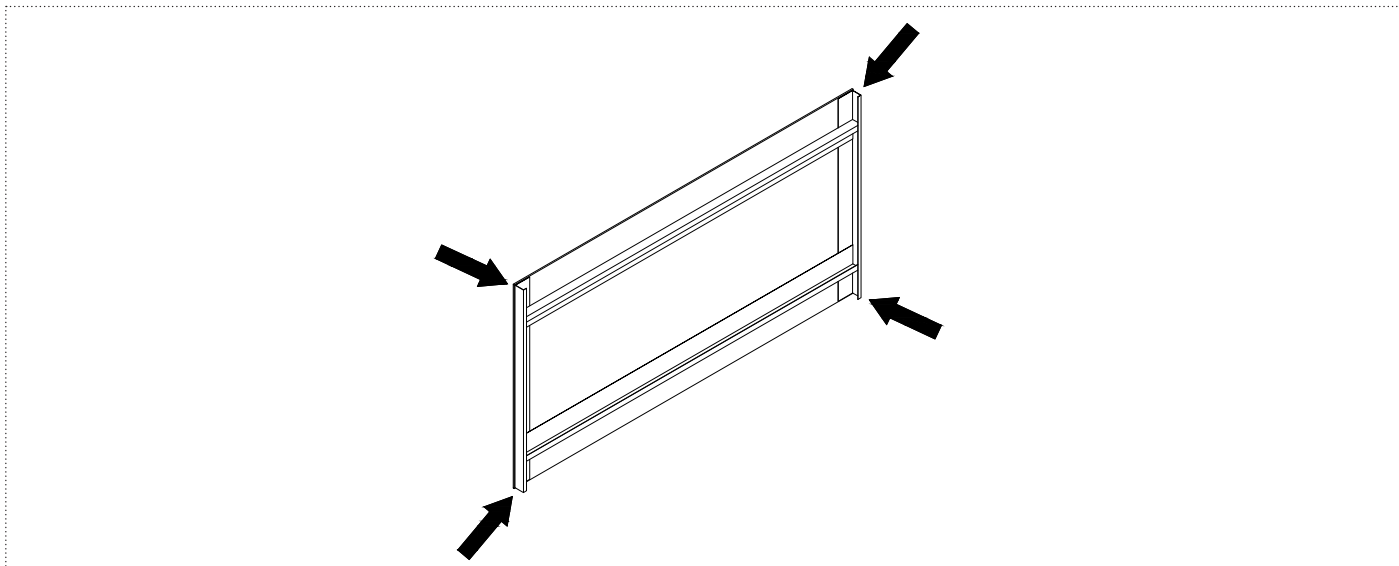

P.S.: REMOVE THE CORNER PROTECTION ONLY WHEN ISNTALLATION IS COMPLETED.
WE ADVISE TO MAKE SURE THE LIGHTING WIRES ARE PREPARED SO THEY ARE IN CORRESPONDENCE TO THE CENTER OF THE MIRROR.

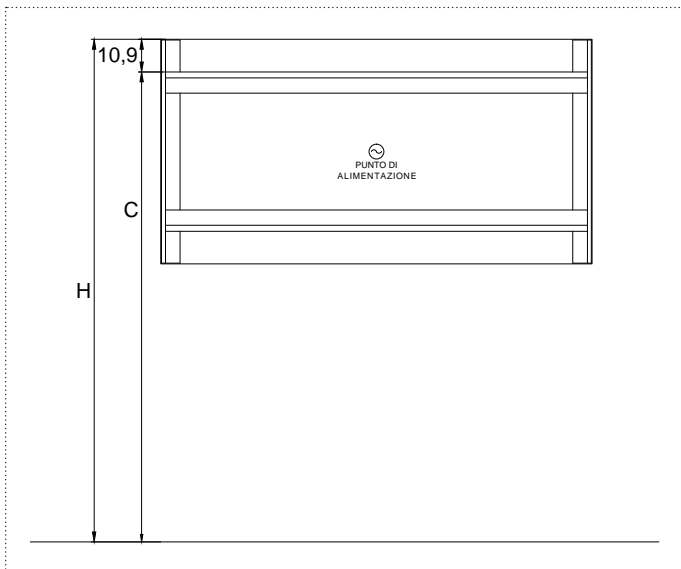

1_ To attach the mirror to the desired height H. Mark the position of the fixing holes of the brackets S, in such a way that the fold of such is located at the height C (C = H - 7,4 cm).

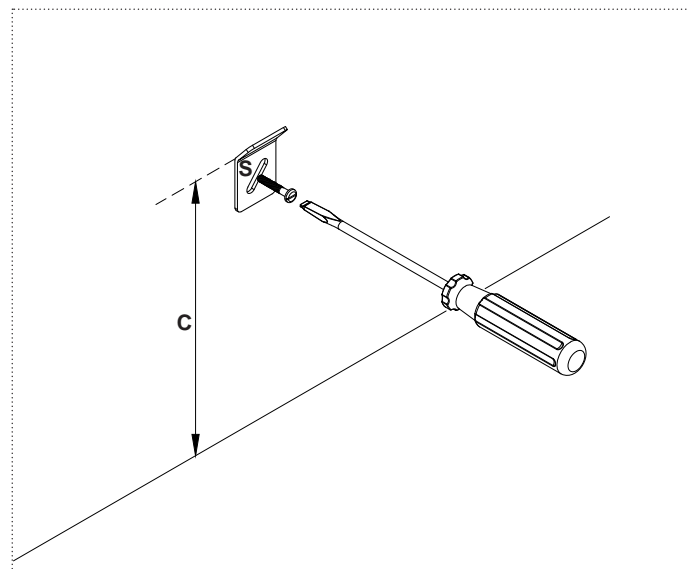

2_ Fix the bracket S at the determined height, put the second bracket in level with the first and fasten it to the wall.

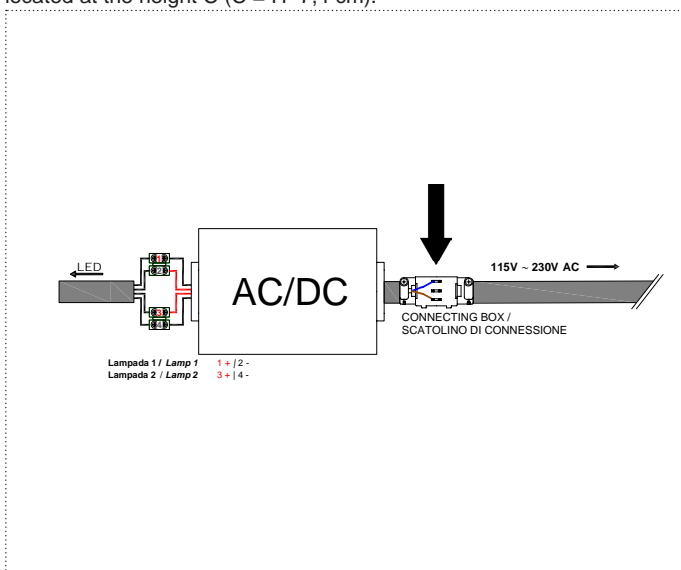

3_ Make the electrical connection between the network and the AC adapter / DC, using the small box of the supplied connection as indicated.

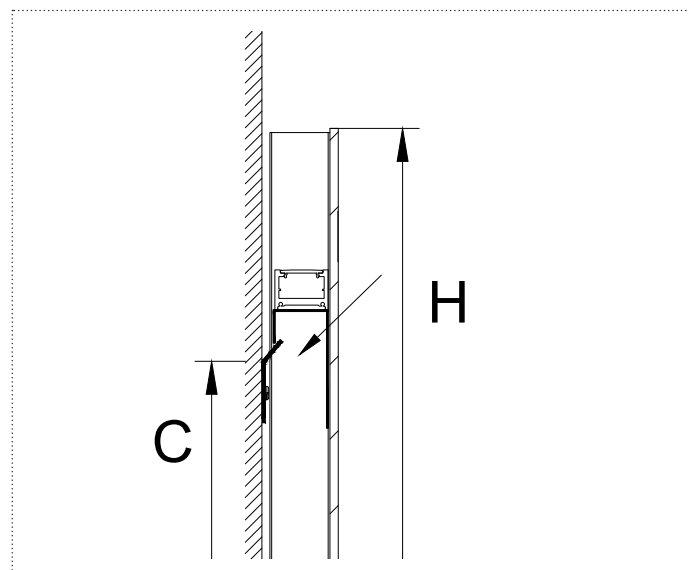

4_ Hang the mirror

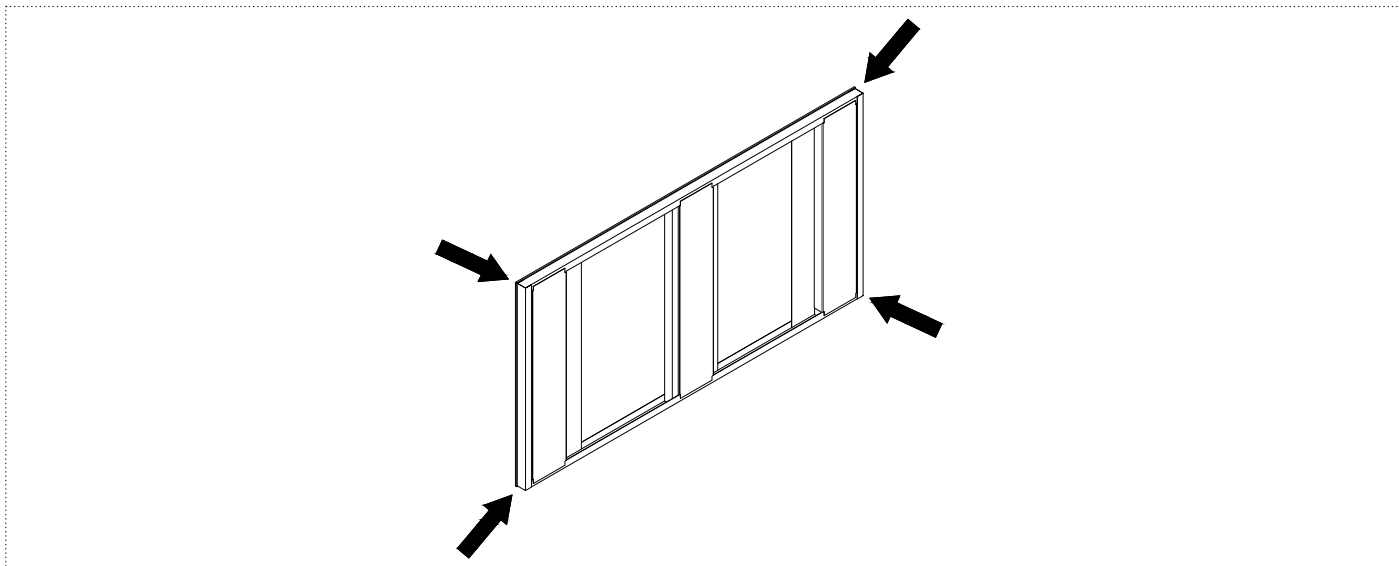

P.S.: REMOVE THE CORNER PROTECTION ONLY WHEN ISNTALLATION IS COMPLETED.
WE ADVISE TO MAKE SURE THE LIGHTING WIRES ARE PREPARED SO THEY ARE IN CORRESPONDENCE TO THE CENTER OF THE MIRROR.

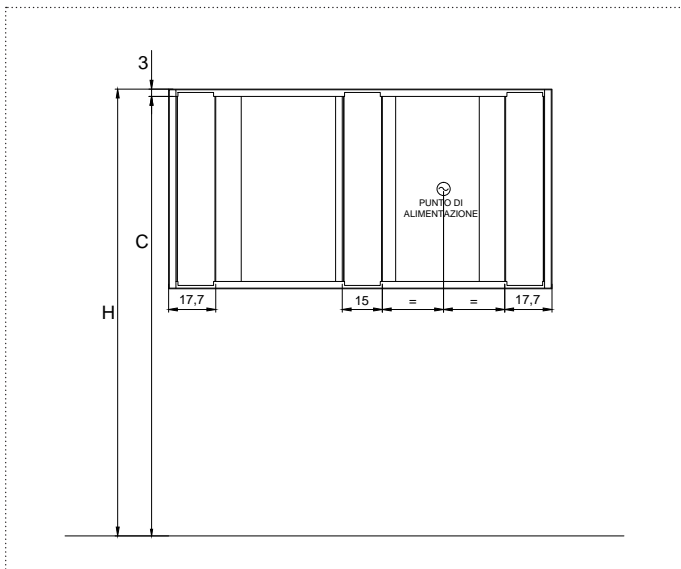

1_ To attach the mirror to the desired height H. Mark the position of the fixing holes of the brackets S, in such a way that the fold of such is located at the height C (C = H - 7,4 cm).

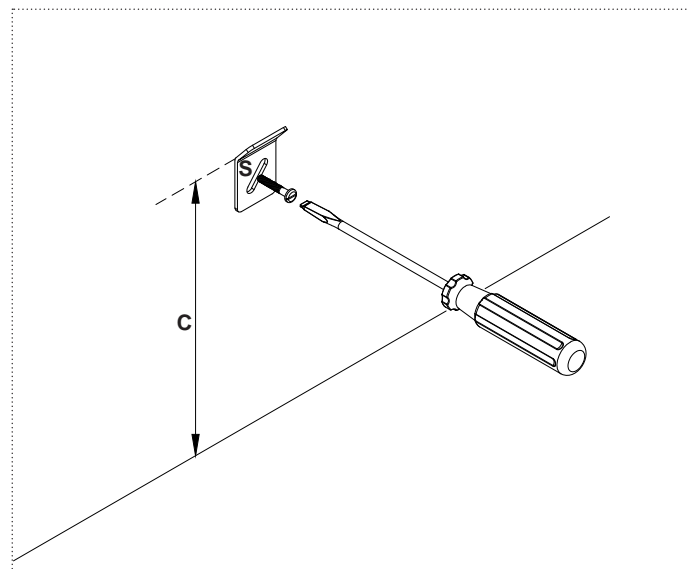

2_ Fix the bracket S at the determined height, put the second bracket in level with the first and fasten it to the wall.

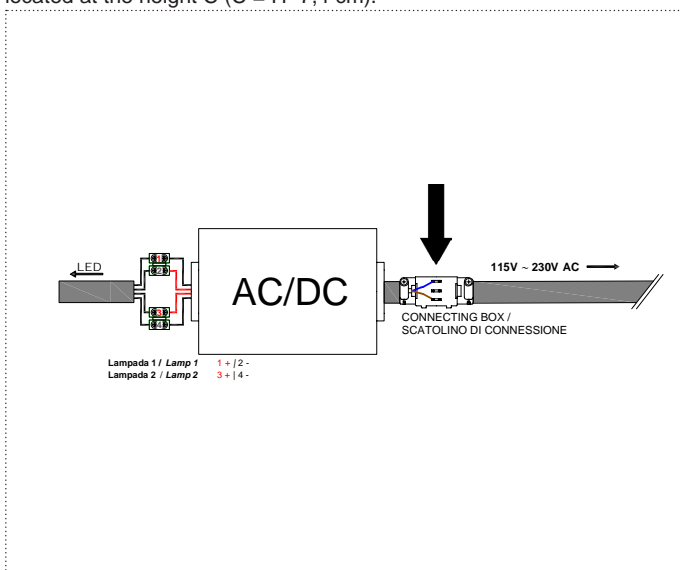

3_ Make the electrical connection between the network and the AC adapter / DC, using the small box of the supplied connection as indicated.

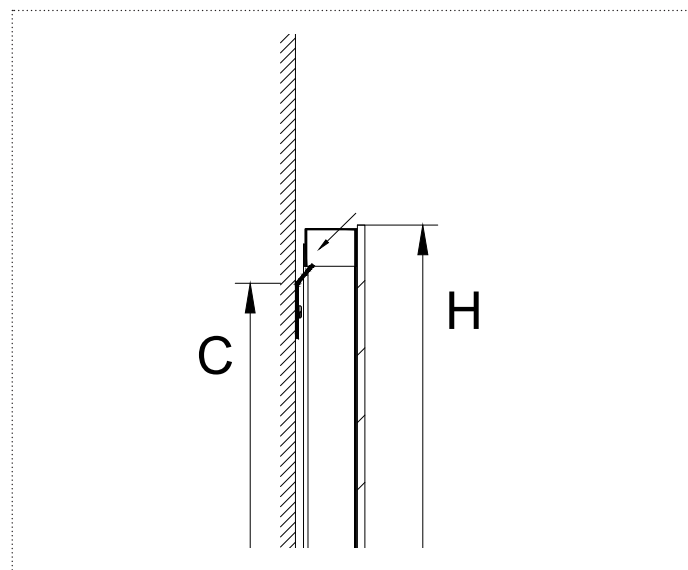

4_ Hang the mirror

