

TECHNICAL DATA

ROLF BENZ 641



**ROLF
BENZ**

- Metal inner frame
- Seat support in wood materials
- Seat in polyurethane foam, built up in coordinated layers varying in height and firmness
- Back and side part with foammoulded metal inner frame; the back is covered with an additional layer of soft foam
- Cover quilted underneath with non-woven polyester
- Four leg version available either without swivel mechanism or with a 360° swivel mechanism (against surcharge)

Finishes:

- Oak H70
- Oak H98
- American walnut H81
- Walnut old grey H82
- Cross base metal options:
with finishes
 - painted RAL 9017 Traffic black
 - painted RAL 7022 Umbra grey
 - high-gloss chrome (price supplement)

! Due to the way the furniture is designed, and its comfort level, some wrinkles and sitting pressure indentations are inevitable, even in top quality Rolf Benz upholstered furniture. All dimensions are approximate.

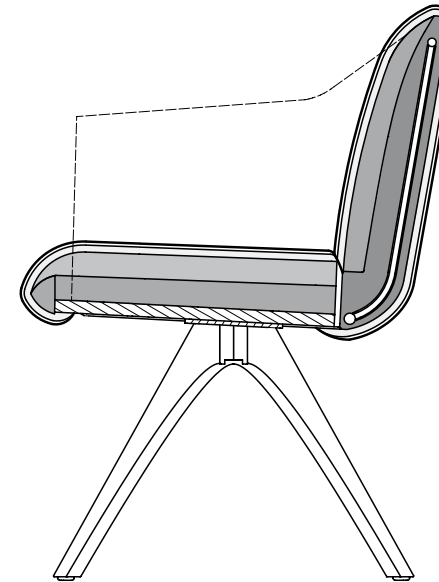

Chair

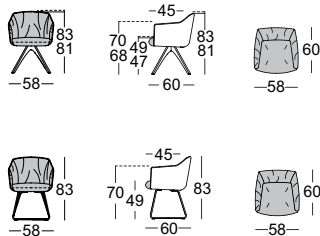

**ROLF
BENZ**