



STEEL

2001 - Gabriele Buratti, Lodovico Acerbis

Description

A sophisticated sideboard with contrasting materials and a bridge design giving it great personality. Particularly wide sideboard supported by two thin and precious sides in mirror polished steel. Featured by a lighting system, placed in a rear technical channel, it allows the light to come at the same time from the upper part, the lower part and inside the casings. A thick wooden back panel makes the unit a free standing sideboard. With flap doors, variously fitted inside with shelves and drawers.

Finishings

Sideboards with flap doors, variously fitted inside with shelves and drawers. Side panels in stainless steel mirror polished. Technical back-end system with back-lighting and cable management. Interior finish matte white. In essence brown oak, lauro preto, Eucalyptus, Black Eucalyptus, or matte and glossy lacquered in 14 colours: Black, White, White SW, Ghiaia Grey, Pietra Grey, Fumo Grey, Lino, Sabbia, Warm Grey, Argilla, Red NY, Red Vico, Blue Iseo, Green Iseo.

Technical info

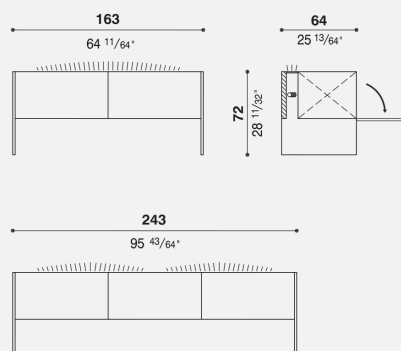

Materials

MOBILE IN ESSENZA:

pannelli di particelle di legno impiallacciati rovere. Verniciatura acrilica, a poro aperto, trasparente opaca.

MOBILE LACCATO:

pannelli di particelle di legno con laccatura lucida oppure con verniciatura poliuretanica goffrata.

FIANCHI:

fianco strutturale composto da pannello di particelle di legno rinforzato con inserti di acciaio e rivestito con lamiera di acciaio Inox lucido.

FASCIA TECNICA E FRONTALE CASSETTI:

metacrilato sabbiato su due lati.

CASSETTI E VASSOI:

pannelli in particelle di legno con verniciatura poliuretanica bianca goffrata.

RIPIANI:

vetro float sabbiato e protetto con vernice poliuretanica.

PORTA CD/DVD:

Alluminio estruso anodizzato colore naturale.

MAINTENANCE NOTES

PARTS WITH A SHINY LACQUER FINISH:

gently rub down with a damp chamois leather or similar (water + a little neutral soap).

STEEL PARTS:

polish with a cloth dampened with water and immediately wipe with a dry cloth. Do not use brushes or sponges made of steel or scratchy materials.

ALUMINIUM PARTS:

gently rub down with a damp cloth (alcohol only).

WOODEN PARTS:

gently rub down with a damp cloth (water only). Do not use alcohol or detergents.

METHACRYLATE PARTS:

Rub smoothly with a dry dust-cloth. Use a damp cloth to remove fingerprints. Do not use alcohol or detergents.

GLASS PARTS:

gently rub down with a damp cloth using any of the products currently available on the market for cleaning glass.

USE CAUTIONS

Important: before replacing the light bulbs, carefully read the technical data and instructions in the light pack. Only qualified professional electricians should service the electrical parts.

Do not use in an improper way. In particular, do not climb or sit on it or rest heavy objects on it or any item for which the product has not been specifically designed.