

TECHNICAL DATA

# ROLF BENZ PLURA



**ROLF  
BENZ**

- Base frame in metal, optionally with surface in
  - Silver structured paintwork finish
  - Black paintwork finish RAL 9017
  - polished chrome
  - painted umbragrey RAL 7022
- Seat heights optionally 41 or 43 or 45 cm
- Seat with metal inner frame and integrated rotary function
- Nosag spring support
- Seat made from polyurethane foam, constructed in layers of different thicknesses and firmnesses, matched to one another, and covered with polyester fleece
- Backrest with metal inner frame and integrated adjustment function
- Back in polyurethane foam built up in coordinated layers of varying height, and firmness and covered with non-woven polyester
- Downy-soft cushions with a filling of foam rods and polyester fibres
- ! Wave formation and depressions in the seat area are unavoidable, due to comfort and design reasons, even in high quality Rolf Benz upholstered furniture. All measurements are approximate.

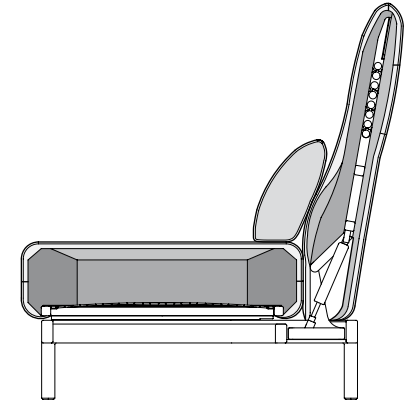
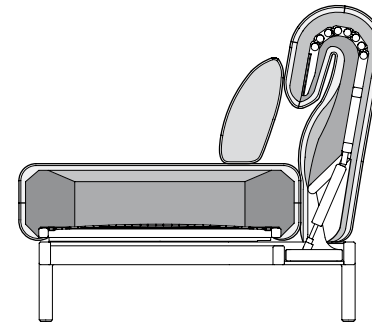

Sofa/Sectional sofa/Corner sectional sofa/  
Longchair

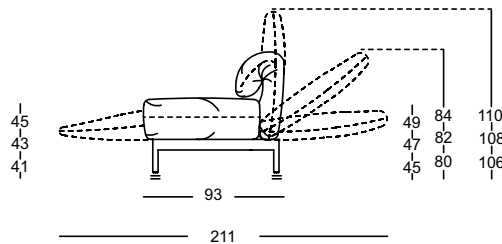

Closing chair with  
fixed footstool

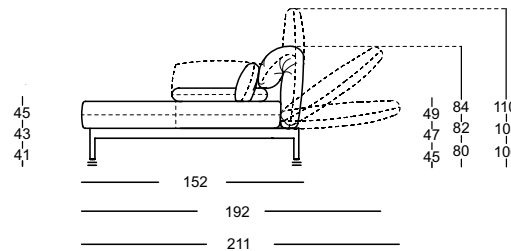

Seat heights available

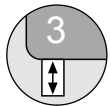

Longchair

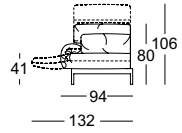

Sofa

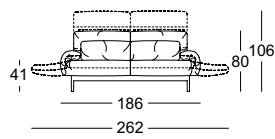

Sectional sofa

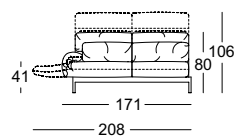

Corner modular sofa element

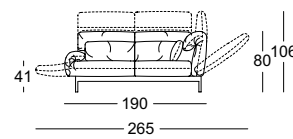

Corner sectional sofa

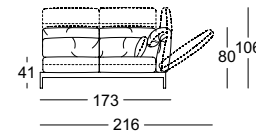

Corner unit

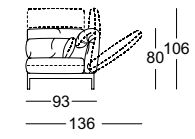

Closing chair with armrest

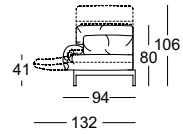

Closing chair with fixed footstool

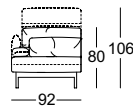

Sectional chair

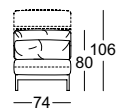

Ottoman



End storage

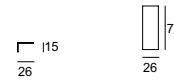

Storage

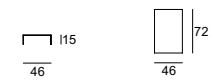

Combination examples:

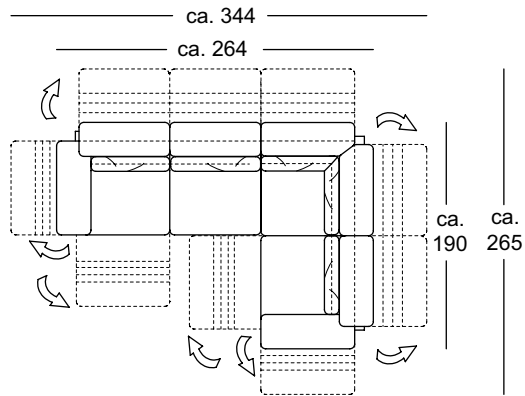

L-ASO-ES 171 le.  
L-E-ASO-ES 190 ri.

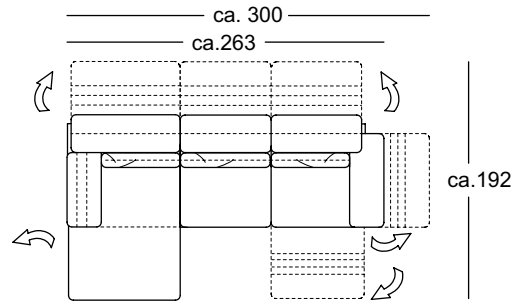

ASS-PSZ 92 le.  
L-ASO-ES 171 ri.

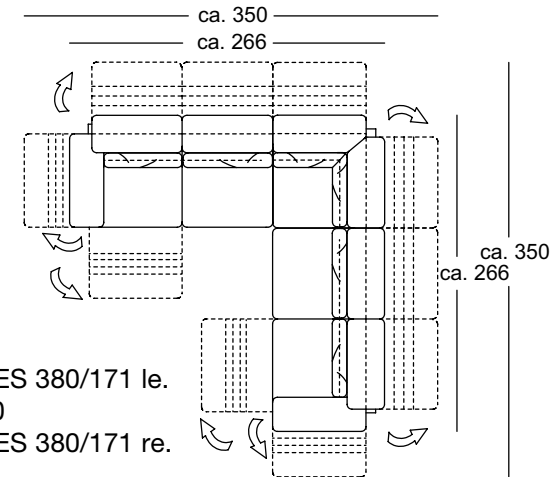

L-ASO-ES 380/171 le.  
EPT 380  
L-ASO-ES 380/171 re.

**ROLF  
BENZ**