

MALTA



design
Gordon Guillaumier 2010

STRUCTURE: wood

FRAME UPHOLSTERY: non-deformable polyurethane 30GRF, 21NF, 25F covered with synthetic lining 150gr which adds softness to the frame

SEAT CUSHION UPHOLSTERY: quilted 100% downproof cotton cover filled with goose down and a resin foam template D30 or non-deformable polyurethane D30 HR3536 covered with Tecnoform Hjet 280 gr/mq

BACK CUSHION UPHOLSTERY: quilted 100% downproof cotton cover filled with mixed down

SPRINGING: elastic belts

SEAT HEIGHT: 45 cm

ARM HEIGHT: 54 cm

FEET: polished or micaceous brown stained aluminium, h. 8 cm

ATTENTION: Only in case of fabric covers, seat and back cushions of sofas and armchairs are reversible

MALTA

Sofa

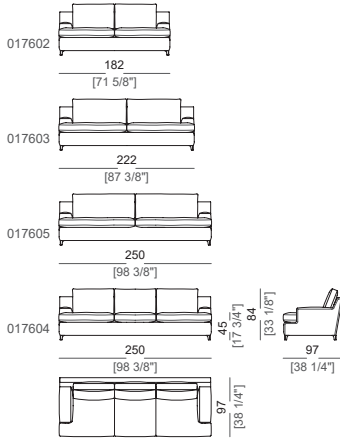

Right or left unit

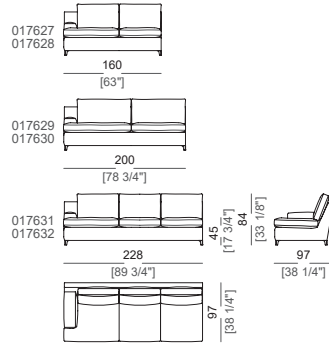

Armchair

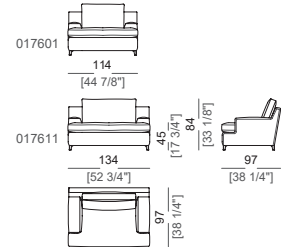

Chaise-longue with right or left short arm

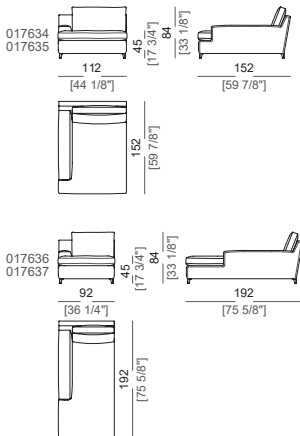

Pouf

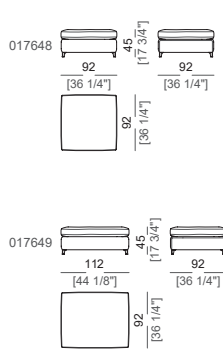

Pouf

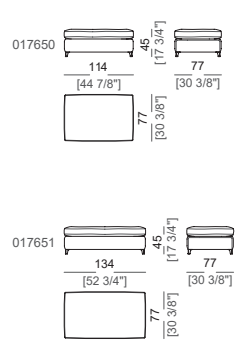

Composition A

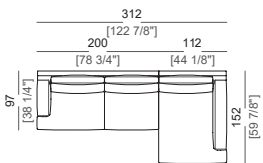

Composition B

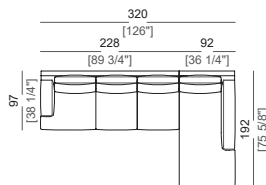

Composition C

